



MODELICA

Proceedings
of the 3rd International Modelica Conference,
Linköping, November 3-4, 2003,
Peter Fritzson (editor)

Niklas Pettersson, Karl Henrik Johansson
Scania; Royal Institute of Technology, Sweden:
Modelica Library for Simulating Energy Consumption of Auxiliary
Units in Heavy Vehicles
pp. 393-398

Paper presented at the 3rd International Modelica Conference, November 3-4, 2003,
Linköpings Universitet, Linköping, Sweden, organized by The Modelica Association
and Institutionen för datavetenskap, Linköpings universitet

All papers of this conference can be downloaded from
<http://www.Modelica.org/Conference2003/papers.shtml>

Program Committee

- Peter Fritzson, PELAB, Department of Computer and Information Science,
Linköping University, Sweden (Chairman of the committee).
- Bernhard Bachmann, Fachhochschule Bielefeld, Bielefeld, Germany.
- Hilding Elmqvist, Dynasim AB, Sweden.
- Martin Otter, Institute of Robotics and Mechatronics at DLR Research Center,
Oberpfaffenhofen, Germany.
- Michael Tiller, Ford Motor Company, Dearborn, USA.
- Hubertus Tummescheit, UTRC, Hartford, USA, and PELAB, Department of
Computer and Information Science, Linköping University, Sweden.

Local Organization: Vadim Engelson (Chairman of local organization), Bodil
Mattsson-Kihlström, Peter Fritzson.

MODELICA LIBRARY FOR SIMULATING ENERGY CONSUMPTION OF AUXILIARY UNITS IN HEAVY VEHICLES¹

Niklas Pettersson^{a,b} Karl Henrik Johansson^b

^aScania CV AB

^bDepartment of Signals, Sensors & System, Royal Institute of Technology

^aScania CV AB, 151 87 Södertälje, Sweden

^bOsquldasväg 10, 100 44 Stockholm, Sweden

niklas.pettersson@scania.se, kallej@s3.kth.se

Abstract

Models that can be used to analyse the fuel consumption of auxiliary units in heavy vehicles are presented. With the purpose of evaluating the influence from various drive concepts and control principals, a model library is developed in the modelling language Modelica. The library contains a mixture of models developed from physical principles and models fitted to collected data. Modelling of the cooling system is described in some detail. Simulation results are compared with measurement data from tests in a wind tunnel.

1 Introduction

This paper presents the work of developing vehicle models that can be used to evaluate alternative architectures for the drive of auxiliary units in heavy vehicles. With aid of the simulation models, the energy savings of new designs can be assessed, (Pettersson and Johansson, 2004). Here the ideas behind development and maintenance of a comprehensive model library are presented. The Modelica language is used to build models with a modular structure. Figure 1 shows composition of the model at the highest level. A more extensive version of the paper can be found in (Pettersson and Johansson, 2003).

In the simulations, the vehicle is set to drive a road with varying topology and speed limit that have been obtained from recordings of real roads. The vehicle is assumed to run on cruise control and with computer-controlled gear shifting (automated manual transmission). Algorithms from the production version of the control are incorporated in the simulation model. The vehicle model has been validated with respect to the energy consumption of

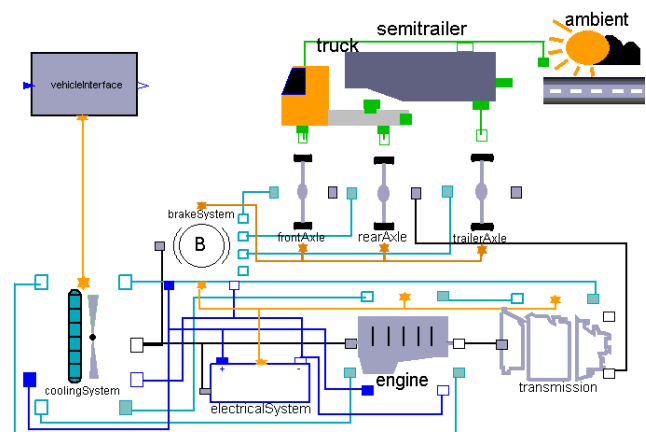

Fig 1. Modules of the simulation model.

the combustion engine and losses such as rolling resistance and air drag, (Sandberg, 2001). Influences from the, sub-systems, the cooling system, and the electrical network, were only included as a lumped effect on the net fuel consumption. This work refines the description of the auxiliary units. The paper describes the modelling of the cooling system in some detail. Sub-models are built from physical principles, resulting in grey-box models with parameters identified from various tests in a laboratory environment.

The sub-models are assembled into a model of the complete vehicle. Measurements collected from tests in a wind tunnel are used to tune the performance of the total model. Validation data is recorded from a dynamic driving cycle in the wind tunnel.

¹ This work is supported by Scania CV AB and Vinnova

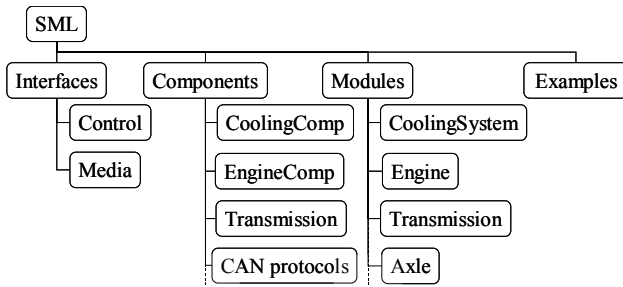

Fig. 2. Structure of the Scania Modelica Library.

2 Model library

The library is developed in Modelica, (Modelica Association, 2000). Modelica is well suited to describe behaviour of complex systems containing parts from different engineering disciplines, e.g., mechanics and electronics.

In contrast to the Modelica Standard Library, the library is not organised in different engineering disciplines. Instead it is organised after the parts of the truck. The library, named Scania Modelica Library, SML, consist of four main branches:

1. Interfaces
2. Components
3. Modules
4. Examples

The principal structure of the library can be viewed in figure 2.

The Interface branch contains classes describing connections between model components. Although the library relies heavily on connector classes defined in the Modelica Standard Library, some unique connectors are defined. One example is the CAN connector, used to mimic the information flow between control units in the truck. Further, under the Interfaces sub-library Media, base classes for thermodynamic and hydraulic models are found. These base classes are mainly used in models of components in the cooling system. In the thermodynamic and hydraulic base classes many of the modelling ideas used are adopted from Modelica library ThermoFluid developed by Thummescheit, et al. (2000). However, here a somewhat simpler structure and less extensive description of media properties are used. In the Components branch models of all physical parts needed to build up the complete model of a truck are gathered. Modules, in the next branch, are a higher level of abstraction, and contain more compound models. The idea is to define a set of generic modules with well-defined

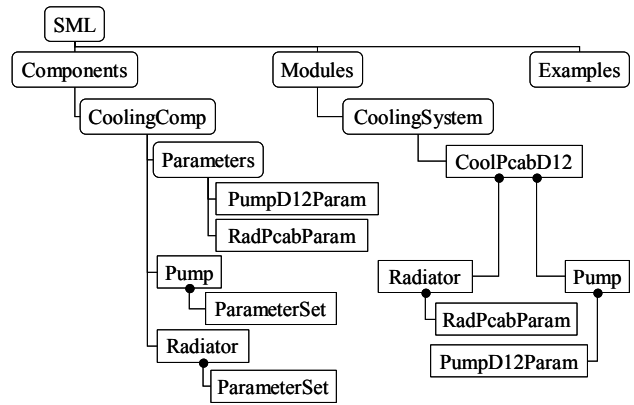

Fig. 3. Parameterisation of the model exemplified with the cooling module.

interfaces that can be used to for simulations with various purposes. In the last branch a number of working examples is built that can be used directly for simulations.

Figure 3 illustrate how the models are parameterised to obtain modules that correspond to physical modules. Each component contains a placeholder for a set of parameters of a defined structure. Parameter sets with values describing various versions of the components are gathered in special sub-libraries. When modules are put together, illustrated with the cooling module, the generic placeholders are replaced with the parameter set of the current versions of components. With this procedure, numerous variants of aggregated modules can be compiled from a small number of basic components and parameter sets.

3 Cooling system module

The cooling system is one of the modules of the vehicle model. Energy consumers in the cooling system are primarily the cooling fan and the water pump.

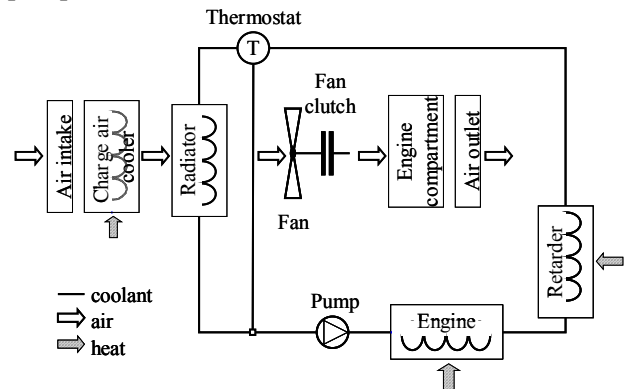

Fig. 4. Components in the cooling system module.

In heavy vehicles, these units normally are mechanically driven. The model corresponds to the current design of a Scania truck where the water pump is directly driven from the crankshaft while the cooling fan is connected to the shaft via a viscous clutch enabling a passive speed control. However, the basic structure allows for changing the model to describe other ways of driving and controlling these auxiliaries.

3.1 Cooling system components

The main parts of the cooling system are modelled, using the thermodynamic and hydraulic base classes. In figure 4 the structure of the cooling system is depicted. The model mainly consists of two adjoining flows of mass and energy: the flow of coolant fluid and the airflow.

The pump drives the flow of coolant fluid through the engine and the retarder. The retarder is a hydraulic brake mounted on the secondary side of the gearbox. When used to brake the vehicle, it produces heat that is emitted to the cooling system. The temperature of the coolant is controlled with the thermostat by splitting up the coolant flow into one part passing the radiator and one part flowing in a by-pass pipe. The air enters the cooling system in the air intake at the front of the truck cab and exits at the air outlet at the rear. The airflow is partly driven by the fan and partly by the pressure build up caused by the wind speed at the intake and outlet. The air is used to cool down both the turbo charged intake air to the engine, and the coolant fluid. The charge air cooler, or intercooler, and the radiator are connected in series so that the cooling air first passes the charge air cooler and then the radiator. Both charge air cooler and the radiator is cross directional heat exchangers, i.e., the hot and cool media streams are perpendicular to each other.

The models of the coolant and the air streams are built up with alternating control volumes and flow models. In the control volumes, mass and energy balances are defined, while in the flow models, relations between the pressure drop and the flow are determined. The control volumes describe the dynamic behaviour and are parameterised purely with geometrical quantities and properties of the contained media. The flow models describe pressure drops, heat transfer and consumed power based on empirical relations. No explicit identification of the parameters of the control volumes is needed, since they could be found in the technical specification of

the components: The parameters of the flow models, however, typically have to be estimated from experimental data.

3.2 Dynamics of the cooling system

For the control volumes it is possible to select which state representation that should be used. The transformation of state variables from the primary mass and energy balances to the selected states is dependent on the properties of the media inside the volume. The modelling of the control volumes is rather standard. Here it essentially follows the principles used in ThermoFluid (Tummescheit et al. 2000).

For the airflow, pressure, p , and temperature, T , are chosen as state variables. The transformed balance equations then become

$$\begin{aligned} m \frac{\partial u}{\partial p} \dot{p} + m \frac{\partial u}{\partial T} \dot{T} &= \dot{U} \\ V \frac{\partial \rho}{\partial p} \dot{p} + V \frac{\partial \rho}{\partial T} \dot{T} + \rho \dot{V} &= \dot{m} \end{aligned} \quad (1)$$

Here \dot{U} and \dot{m} denote the net flow of energy and mass into the control volume while m and V are the mass trapped in the volume and the size of the volume, respectively. Additionally, the air is regarded as an ideal gas yielding the following expressions for the density, ρ , and the partial derivatives in equation (1)

$$\begin{aligned} \rho &= \frac{pM}{TR} \\ \frac{\partial u}{\partial p} &= 0, \quad \frac{\partial \rho}{\partial p} = \frac{M}{TR} \\ \frac{\partial u}{\partial T} &= c_v, \quad \frac{\partial \rho}{\partial T} = -\frac{pM}{T^2 R} \end{aligned} \quad (2)$$

where M denotes the molar mass and c_v the specific heat capacity at constant volume, respectively, while R is the molar gas constant.

Similar expressions are used for the state derivatives of the coolant media, although only the temperature is chosen as state variable. The pressure of the coolant is determined purely from static hydraulic relationships.

3.3 Parameters of the flow models

For the airflow, pressure drops in the components along the flow path are modelled as an exponential friction loss

$$\Delta p = c |q| \dot{m}^e \quad (3)$$

The frictional pressure losses in the components coolant path is modelled with a second order polynomial

$$\Delta p = c_2 |q| q + c_1 q \quad (4)$$

The pressure rise in the pump and the fan depend on the flow through the components and the angular velocity of the shaft. In the model the following equations are used to describe the operation of the pump and the fan, respectively

$$\Delta p = R_1 |\omega| \omega + 2R_2 \omega q - R_3 |q| q \quad (5)$$

$$\Delta p = R_1 \rho |\omega| \omega + 2R_2 \omega \dot{m} - R_3 |q| \dot{m} \quad (6)$$

In equation (3)–(6), q and \dot{m} denotes volume flow rate and mass flow rate, respectively, while ω denotes the angular velocity of the pump or the fan.

The wind speed gives rise to a differential pressure at the air intake and outlet relative the ambient pressure. In the model, the pressure difference depends on the wind speed, v , the air density, ρ , and the non-dimensional coefficient CD according to

$$\Delta p = CD \frac{\rho}{2} v^2 \quad (7)$$

In order to find the parameter values of the sub-models, experimental data is collected from tests on individual components in a laboratory environment. Essentially parameters of equation (3)–(7) and other characteristics are identified for each component depicted in the overview of the cooling module in figure 4. Table 1 summarises which parameters that are identified and what data that are used.

Table 1 Summary of model components in the cooling module.

Component	Characteristic	Data source	Slack
Pump	- Pressure rise - Power consumption	Rig test Rig test	s
Engine	- Flow resistance - Heat capacitance - Heat emission to coolant - Heat emission from charge air	Rig test Data sheet Rig test Rig test	s
Retarder	- Flow resistance - Heat capacitance - Heat emission	Rig test Data sheet None	s
Thermostat	- Opening characteristic - Flow resistance - Dynamic response	Rig test Rig test Rig test	
Radiator	- Flow resistance coolant - Flow resistance air - Operating characteristics - Heat capacitance	Rig test Rig test Rig test Data sheet	
Air intake	- Pressure build-up	None	s
Charge air cooler	- Flow resistance	Rig test	s
Fan	- Pressure rise - Power consumption	Rig test Rig test	
Fan clutch	- Slip characteristics	Rig test	
Engine compartment	- Flow resistance	Rig test	
Air outlet	- Pressure build-up	None	s

Input from other parts of the total model is primarily heat losses that need to be cooled away. The engine emits heat to the cooling system both directly into the engine block, which is heated up by the combustion, and through the cooling of the charge air. The amount of heat depends on the current torque and speed of the engine.

In the model this is calculated from a look-up table. The table is obtained from measurements done in test cells. The heat emitted to the cooling system from the retarder is directly proportional to the braking power. In some sub-models, the parameters solely represent basic quantities such as mass or volume that are found from the data sheet of the corresponding component. The tests are performed in the laboratory under well-controlled conditions. As a result the obtained prediction errors are very small as can be seen by the example in figure 5, showing the pressure drops in the airflow path.

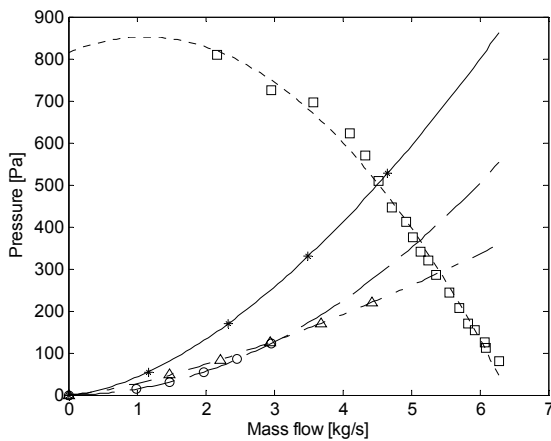

Fig. 5. Pressure drop as a function of airflow for the charge air cooler model (solid) compared with measurements (stars). Corresponding drops for radiator (dashed and triangles), and engine compartment (dash-dotted and circles). Pressure rise of the fan model (dotted) at 1400 rpm compared with measurements (squares).

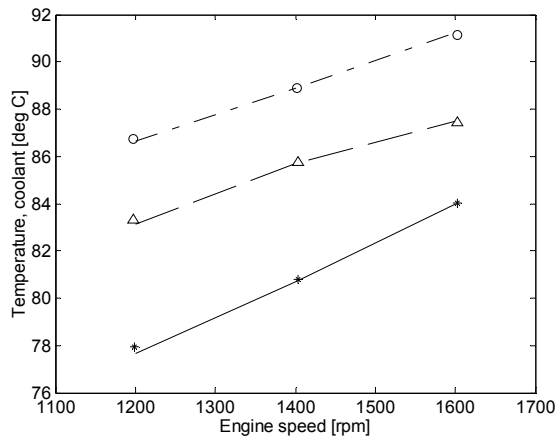

Fig. 6. Simulated temperature of the coolant in steady state at 80 km/h with full load and different speeds on the engine (solid) compared with measurements (stars). Corresponding at 60 km/h (dashed and triangles) and at 40 km/h (dash-dotted and circles).

4 Assembling the total model

The modelling errors in the sub-models are very small. However, when they are assembled to a full model, effects that are not handled in the sub-models may play an important role. It may be effects from the installation the truck cab such as the piping between the components. Non-linearities may amplify small errors in the sub-models when these are connected and new feedback paths are closed. It can be shown, using a simplified model of the cooling system, that the change of temperature of the coolant in steady state due to a small perturbation of the airflow is proportional to the squared inverse of the airflow. Thus, the simulated temperature will be very sensitive to modelling errors influencing the airflow. Further, for the pressure build-up due to the wind speed there exists no practicable experiment on a component level. Therefore, the result of the total model is verified through comparison with experimental data collected in a wind tunnel. In the wind tunnel, the vehicle is driven on a dynamometer with a defined load and speed of the engine. Fans are used to simulate the wind speed. Results from nine steady-state tests and two step-response tests are used to tune the model parameters. A number of the parameters in the sub-models are assigned as slack parameters that are adjusted to fit the behaviour of the total model to the measurements. In table 1 the choice of slack parameters is indicated in the last column. In figures 6 and 7 the cooling temperature obtained with the tuned model are compared with measurements.

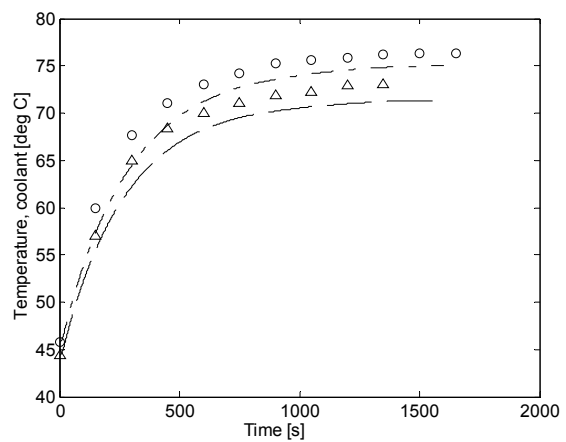

Fig. 7. Simulated response of the coolant temperature on a step in the engine load at 60 km/h with engine speed 1400 rpm (dashed), compared with measurements (triangles). Corresponding at 40 km/h (dash-dotted and circles).

Validation of the total model is performed. Data is recorded during a dynamic drive cycle in the wind tunnel, where the load and speed of the dynamometer is programmed to follow a cycle corresponding to a specified road. In figure 8 the simulation result is compared with measurements where the dynamometer follows the profile of a 57 km section of the road between the cities Koblenz and Trier in Germany. The validation shows that the model is capable to capture the main dynamics of the cooling system while it does not describe the small oscillations observed in the measurements. The oscillations around 80° C most likely have its origin in the complex dynamics of the thermostat. The model of the thermostat is a rather rough approximation and do not give raise to corresponding oscillations around the opening temperature. Despite the observed differences, the model should be sufficient to evaluate the energy consumption of the auxiliary units in the cooling system.

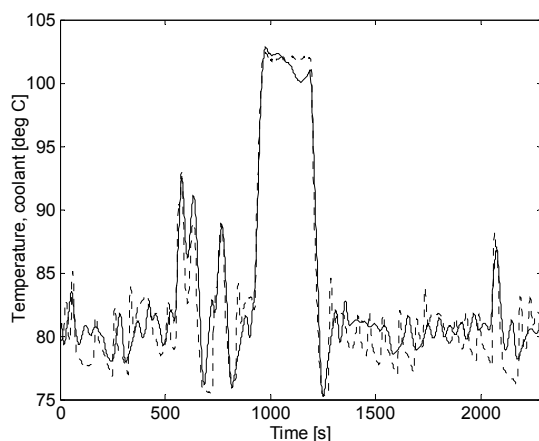

Fig. 8. Simulated coolant temperature (solid) during a dynamic driving cycle compared with measurements (dotted).

REFERENCES

- Modelica Association, (2002). Modelica™ - A Unified Object-Oriented Language for Physical Systems Modeling. *Language Specification Ver2.0*. <http://www.modelica.org/>, 2002.
- Pettersson, N., Johansson K. H., (2003). Simulating energy consumption of auxiliary units in heavy vehicles. *Proceedings of 13th IFAC Symposium on System Identification*.
- Pettersson, N., Johansson K. H., (2004). Optimal control of the cooling system in heavy vehicles. *Proceedings of IFAC Symposium on Advances in Automotive Control*.
- Sandberg, T., (2001). *Heavy Truck Modeling for Fuel Consumption Simulations and Measurements*. Licentiate thesis, department of Electrical Engineering, Linköping University Sweden.
- Tummesheit, H., Eborn J. and Wagner FJ., (2000). Development of a Modelica Base Library for Modeling of ThermoHydraulic Systems. *Proceedings of Modelica Conference 2000*.