



MODELICA

Proceedings
of the 3rd International Modelica Conference,
Linköping, November 3-4, 2003,
Peter Fritzson (editor)

Francesco Casella, Alberto Leva
Dipartimento di Elettronica e Informazione, Politecnico di Milano:
Modelica open library for power plant simulation: design and
experimental validation
pp. 41-50

Paper presented at the 3rd International Modelica Conference, November 3-4, 2003,
Linköpings Universitet, Linköping, Sweden, organized by The Modelica Association
and Institutionen för datavetenskap, Linköpings universitet

All papers of this conference can be downloaded from
<http://www.Modelica.org/Conference2003/papers.shtml>

Program Committee

- Peter Fritzson, PELAB, Department of Computer and Information Science, Linköping University, Sweden (Chairman of the committee).
- Bernhard Bachmann, Fachhochschule Bielefeld, Bielefeld, Germany.
- Hilding Elmqvist, Dynasim AB, Sweden.
- Martin Otter, Institute of Robotics and Mechatronics at DLR Research Center, Oberpfaffenhofen, Germany.
- Michael Tiller, Ford Motor Company, Dearborn, USA.
- Hubertus Tummescheit, UTRC, Hartford, USA, and PELAB, Department of Computer and Information Science, Linköping University, Sweden.

Local Organization: Vadim Engelson (Chairman of local organization), Bodil Mattsson-Kihlström, Peter Fritzson.

Modelica open library for power plant simulation: design and experimental validation

Francesco Casella, Alberto Leva*

Dipartimento di Elettronica e Informazione, Politecnico di Milano
Via Ponzio, 34/5 - 20133 Milano (Italy)

Abstract

The open Modelica library ThermoPower for the simulation of thermal power plants is presented, by illustrating the modelling principles and the main features of the developed models. The library has been validated against experimental data coming from a laboratory drum boiler, and the main results are shown in the paper. The library, plant model, and validation data are publicly available through the Web.

1 Introduction

Dynamic simulation plays a key role in the design of the control system of thermal power generation plant, in particular when innovative design efforts are undertaken. There is a long track of research and engineering effort in this field, dating from the pioneering paper [8] through [10, 14, 1, 13] and numerous other works. Also, many software packages have been developed in the academic as well as commercial field, see e.g. [4, 7, 19, 3, 2, 20, 17, 11, 15] and, in particular, [16]. Commercial modelling tools often suffer from the drawback of being opaque: it is not clear to the user which equations are actually been used to describe a certain component, and it is hard, if not impossible, to incorporate the user's specific know-how in the model library [6]. Conversely, in university laboratories many tools have been developed, in which the user has full control over the model equations; however, due to the intricacies of modelling thermo-hydraulic systems and to the difficulty of integrating the corresponding equations [14], ad-hoc modelling paradigms and software packages are employed, which are neither interchangeable nor interoperable with each other, not to mention their actual availability.

Moreover, when it comes to validating the models, it is very difficult to obtain complete and accurate ex-

perimental data sets from real plants [12]. Therefore, there is a strong need for shared and agreed-on models, which can be actually run by by currently available simulation tools, as well as of benchmark data for model validation. The adoption of the Modelica language is a great opportunity in this direction.

The goals of the research work presented in this paper can be summarised as follows.

1. Develop an open Modelica library for the modelling of thermal power plants based on first principle models, which is highly readable and extensible, and where models of the same physical component with different level of detail may co-exist.
2. Demonstrate that models of real-life complexity can be dealt with by current Modelica tools.
3. Validate the library against experimental data from a laboratory plant.
4. Make the library code and the experimental data available to the scientific community.

The paper is organised as follows: Section 2 summarises the principles by which the entire library has been structured; Section 3 discusses the modelling assumptions and the main features of the developed models, while Section 4 is devoted to a brief description of the laboratory plant and of the experimental data set; in Section 5, the main results obtained with the plant simulator are shown. Conclusions and perspectives for future work are given in Section 6.

2 The library principles

This section outlines the principles of the presented library, motivating the adoption of Modelica as the host environment. A more detailed discussion is reported in [6], to which the interested reader is referred, while a

*Corresponding author, e-mail leva@elet.polimi.it

longer explanation of the modelling principles adopted in the library can be found in [13].

Use of first-principle equations. The equations of the library models are derived from mass, energy and momentum balances, and (when necessary) from well established empirical correlations. Therefore, all the quantities involved in the models can be given a physical meaning.

Openness and transparency. The features of Modelica are exploited to obtain a code that tightly matches the way describing equation are written on paper. This greatly facilitates documenting and maintaining the library, and allows the users to understand exactly what they are simulating. Also, Modelica's powerful syntax can be exploited to investigate different modelling options quickly, and the inherently open nature of the environment permits modifications and improvements with a limited effort.

Readability-reusability trade-off. The inheritance mechanism is used sparingly, and with great care. Even though inheritance appears very attractive when structuring a component library, it is very difficult to define sufficiently general basic models in the application domain addressed here. Moreover, in a complex hierarchy of models, modifying the equations of some ancestor could have unexpected effects on the siblings, potentially impairing readability, not to say correctness. Since even fairly complex models can be described with a few dozen lines of code, it is advisable that the behaviour of a single component be described in a single place, rather than scattered through many different classes. Inheritance should be limited to the definition of 'prototype' components, i.e. partial classes containing connector declarations and auxiliary equations such as $\Delta p = p_{in} - p_{out}$. In the library there is one notable exception to this design principle, see section 3.4.1.

Partial Differential Equations. For the purposes of this work, models based on 1-dimensional partial differential equations are needed, which are not supported by Modelica in their native form. Therefore, such equations are reduced to ordinary differential ones by appropriate methods (e.g. finite volumes, finite elements) prior to their insertion in a Modelica model.

Standard interfaces. In the library, connectors are designed so as to be totally independent of the modelling assumptions adopted for the component. The same terminals are used no matter whether the fluid is assumed to be one- or two-phase, the model is lumped- or distributed-parameter, the momentum balance is static

or dynamic, the cross-sectional fluid velocity distribution is uniform or not, the phases in two-phase flows are assumed to have the same velocity or not, and so forth. To clarify with an example, we report the definition of the `waterFlangeA` and `waterFlangeB` connectors, which describe the flanges of the components that carry a water/steam flow:

```
connector WaterFlangeA
  Pressure p;
  flow MassFlowRate w;
  input SpecificEnthalpy hBA;
  output SpecificEnthalpy hAB;
end WaterFlangeA
connector WaterFlangeB
  Pressure p;
  flow MassFlowRate w;
  input SpecificEnthalpy hAB;
  output SpecificEnthalpy hBA;
end WaterFlangeB
```

In the code `p` is the fluid pressure, `w` is the mass flowrate entering the component, `hAB` and `hBA` are the specific enthalpies of the fluid in case its direction is from an A-type flange to a B-type flange and vice-versa. Correct models are obtained by always connecting two flanges of complementary type. These connectors allow to deal with flow reversal in a very straightforward way, as witnessed by the following code describing a simple constant-volume vessel.

```
model SimpleMixer
  parameter Volume V=0 "Inner volume";
  FlangeA in; FlangeB out;
  Pressure p; Density rho;
  SpecificEnthalpy h,hi,ho;
  DerDensityByPressure drdp;
  DerDensityByEnthalpy drdh;
equation
  (rho,drdp,drdh) = prop_ph(p, h);
  V*(drdp*der(p)+drdh*der(h)) = in.w+out.w;
  V*((h*drdp-1)*der(p)+(rho+h*drdh)*der(h)) =
    in.w*hi+out.w*ho;
  hi = if in.w >= 0 then in.hBA else h;
  ho = if out.w >= 0 then out.hAB else h;
  in.hAB = h; out.hBA = h;
  in.p = p; out.p = p;
end SimpleMixer;
```

The paradigm of connectors is exploited to standardise also the interfaces involving 1-dimensional distributed quantities used in modelling components like heat exchangers. Such connectors are characterised by a number of uniformly spaced nodes, and contain the nodal values of the quantities under question, no matter how the spatial discretisation is dealt with inside the component. An example is the `DHT` connector, whose definition is

```
connector DHT;
  parameter Integer N=2 "Number of nodes";
  Temperature T[N];
  flow HeatFlux phi[N];
end DHT;
```

Flexible level of detail. Encapsulation is exploited to allow for models with different degrees of detail, and fully interchangeable. This means that, in different situations, the same component or part of the plant can be modelled with different detail levels, with a small effort on the part of the analyst.

Substance property calculation. Medium models for water, steam, and ideal gas mixtures are already provided by the free Thermofluid library [21]. Simulation efficiency could possibly be increased by using third-party property calculation packages written in C or FORTRAN. The library is open to such extensions.

Models for different fluids. It would be possible to make the equations of a component highly independent of the fluid contained, thus reducing the total number of library components. This is not very convenient for the presented library, however. In thermal power plants there are essentially two fluids (water/steam and ideal gas mixture), and the thermo-hydraulic phenomena involving these fluids are described by equations that can be very different also from the structural standpoint. Therefore, attempting to write equations in a ‘general’ form involves a significant complication of the equations themselves. It is preferable to write specialised models for the two fluids, and this is the approach adopted. The same specialisation applies to connectors, of course.

A great number of modelling environments and libraries for power plant simulation are available in the literature, see e.g. [4, 7, 19, 2, 20, 11, 15, 5], and in the last years several were developed within the Modelica environment (a remarkable example is [21]). There is not the space to give an exhaustive review here. However, two peculiarities of the proposed modelling approach, and therefore of the library, are worth pointing out. The first, as already mentioned, is the ‘flat’ structure of the model hierarchy, aimed at maximising the readability. The second is that, by writing the models as is done here, one can (but is not obliged to) reach the maximum level of detail that is advisable for simulations aimed at system-oriented studies, i.e., for example, at the synthesis and validation of the control system.

3 Developed models

3.1 Boundary conditions

Ideal pressure sources and sinks have been defined (`SourceP`, `SinkP`), as well as mass flowrate sources

and sinks (`SourceW`, `SinkW`); note that the difference between source and sink is purely conventional, as both of them can handle flow in either direction. Hydraulic and thermal variables can be either constant, or determined by external signals.

3.2 Branching components

Flange terminals only support connection of *two* components; therefore, the `FlowJoin` and `FlowSplit` components are provided to model flow branching. The model are based on static mass and energy balances equations, supporting all the feasible flow directions and avoiding numerical singularities.

3.3 Elementary physical components

3.3.1 Valves

The `ValveLiq` and `ValveVap` models are based on the standard IEC 535 sizing equations for valves with liquid and vapour flow, respectively; critical flow can be modelled in both cases, as well as check valve behaviour. Flow reversal is supported, avoiding numerical singularities for small or zero pressure drop. The opening characteristic can be customised.

3.3.2 Mixers, collectors, tanks

The `Mixer` and `Collector` models are based on standard mass and energy balances, assuming uniform pressure and temperature in the control volume; they differ only by the number of connecting flanges. Heat exchange with the metal wall can be also accounted for. Tank models a gas-pressurised tank, with gas charge and discharge valves.

3.3.3 Pumps

Since storage of mass and energy are negligible, the `PumpMech` model is expressed by algebraic characteristic equations derived from the manufacturer’s design data, that relate the pump head and the resistant hydraulic torque applied by the fluid to the shaft to the rotation speed and the volumetric flow rate. A boolean parameter allows to account for the total rotor inertia, when required. It is also possible to use the simpler model `Pump`, where the rotation speed is an input signal, the hydraulic torque is not computed, and a constant efficiency is assumed to determine the enthalpy difference between the inlet and the outlet.

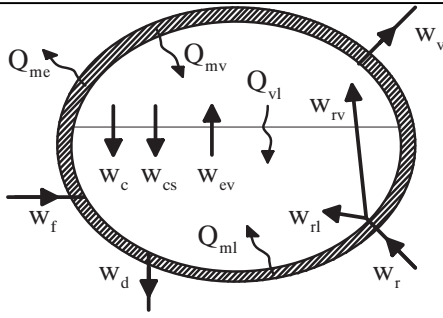

Figure 1: Steam drum.

3.3.4 Drum

The DRUM model is the core of drum boilers models [9, 14]. In order to describe correctly the dynamics of fast transient, the model does not assume that the liquid and vapour phase are in thermodynamic equilibrium, i.e. at saturation state. Referring to figure 1, the basic equations are mass and energy balances for the liquid and vapour phases:

$$\frac{dM_v}{dt} = w_{rv} + w_{ev} - w_v - w_c - w_{cs} \quad (1)$$

$$\frac{dM_l}{dt} = w_f + w_{rl} + w_c + w_{cs} - w_d - w_b - w_{ev} \quad (2)$$

$$\begin{aligned} \frac{dE_v}{dt} = & w_{rv}h_{rv} + w_{ev}h_{vs} - w_vh_v - w_ch_{ls} - w_{cs}h_{vs} + \\ & + Q_{mv} - Q_{vl} - p \frac{dV_v}{dt} \end{aligned} \quad (3)$$

$$\begin{aligned} \frac{dE_l}{dt} = & w_fh_f + w_{rl}h_{rl} + w_ch_{ls} + w_{cs}h_{vs} - w_dh_d + \\ & - w_bh_l - w_{ev}h_{vs} + Q_{ml} + Q_{vl} - p \frac{dV_l}{dt} \end{aligned} \quad (4)$$

$$\frac{dE_m}{dt} = -Q_{ml} - Q_{mv} - Q_{me}, \quad (5)$$

where M_v , M_l , E_v , E_l , V_v , V_l are the mass, internal energy, and volume of the vapour and liquid phase holdups, E_m is the thermal energy of the metal wall, p is the drum pressure, w is a mass flowrate, h is a specific enthalpy, Q is a heat flow. The meaning of the subscripts is: *rv*: risers (vapour fraction), *rl*: risers (liquid fraction), *l*: liquid phase, *v*: vapour phase, *c*: condensation, *cs* superficial condensation, *ev*: evaporation, *f*: feed, *d*: downcomer, *b*: blowdown, *vs*: saturated vapour, *ls*: saturated liquid.

The bulk and superficial condensation flowrates, evaporation flowrate and convective heat exchange between the two phases are computed according to

$$w_c = \frac{(1 - x_v)\rho_v V_v}{\tau_c} \quad (6)$$

$$w_{cs} = K_{cs}A_{sup}(T_s(P) - T_l) \quad (7)$$

$$w_{ev} = \frac{x_l \rho_l V_l}{\tau_{ev}} \quad (8)$$

$$Q_{vl} = K_{sup}A_{sup}(T_v - T_l) \quad (9)$$

where ρ_l , ρ_v , T_l , T_v are the liquid and vapour densities and temperatures, x_l , x_v are the steam qualities in the liquid and vapour phases, τ_c , τ_{ev} are suitable time constants, A_{sup} is the area of the liquid surface, and K_{cs} , K_{sup} are suitable coefficients. The (non ideal) phase separation at the risers outlet is modelled as follows: h_{rl} is the saturated liquid enthalpy at the drum pressure, while h_{rv} is such that the corresponding steam quality is $1 - (\rho_v/\rho_l)^\alpha$.

The model is implemented in order to have the following state variables: drum pressure, liquid and vapour enthalpy, level, and metal wall temperature.

3.4 Building blocks for complex components

3.4.1 1-dimensional fluid flow

The FLOW1D model describes the 1-dimensional flow of single-phase water in a tube of constant cross-section. The basic equations are the distributed-parameter mass, momentum, and energy balances:

$$A \frac{\partial p}{\partial t} + \frac{\partial w}{\partial x} = 0 \quad (10)$$

$$\frac{\partial w}{\partial t} + A \frac{\partial P}{\partial x} + \rho g A \frac{dz}{dx} + \frac{C_f \omega}{2\rho A^2} w|w| = 0 \quad (11)$$

$$\rho A \frac{\partial h}{\partial t} + \rho A u \frac{\partial h}{\partial x} - A \frac{\partial p}{\partial t} = \omega \varphi \quad (12)$$

where ρ is the fluid density, w is the mass flowrate, p is the pressure, A is the tube cross-section, g is the acceleration of gravity, z is the elevation, C_f is the Fanning friction coefficient, ω is the tube perimeter, u is the fluid velocity, h is the fluid enthalpy and φ is the heat flux entering the tube across the lateral surface. Equations (10)–(11) describe the fast pressure and flowrate wave dynamics, while Eq. (12) describes the slower dynamics of heat transport with the fluid velocity; the equations are then discretised with the finite volume method, considering a single volume for the former two (which need a coarser approximation in the frequency range of interest for power generation models), and many volumes for the latter.

Among the relevant features of this model, the following ones are worth mentioning: flow reversal is fully supported; the dynamic momentum term $\partial w/\partial t$ can be switched off to avoid fast pressure oscillations; the C_f coefficient can be either constant or computed by the

Colebrook equation; the compressibility effect resulting from the finite volume approximation of (10) can be associated to either the upstream or downstream pressure; a bank of identical tubes in parallel can also be modelled.

The `Flow1D2ph` model can also deal accurately with two-phase flow; although being based on the same equations (10)–(12), the significant differences with respect to `Flow1D` suggest writing two completely independent models.

The `Flow1DDB` model extends (in Modelica's terms) `Flow1D` by also computing the heat transfer coefficient γ via Dittus-Bölder's equation; correspondingly, the `DHT` connector (which is replaceable) is substituted by the extended `DHThtc` connector, which makes the values of γ visible to the outside. To describe the superheater, where the fluid is *slightly* wet or superheated steam, the `Flow1D2phDB` model was created, which still computes the heat transfer coefficient with Dittus-Bölder's equation, but accounting only for the vapour fraction.

3.4.2 Pressure drop

The `PressDrop` model provides the model for a generic pressure drop proportional to the kinetic pressure. The equation is modified by adding a small linear term, to avoid singularities with small or zero flowrates, thus reading:

$$p_{in} - p_{out} = \frac{K_f(|w| + Kl)w}{\rho} \quad (13)$$

The same modification also applies to the models described in section 3.4.1.

3.4.3 Metal wall

The `MetalWall` model describe a generic cylindrical metal wall, accounting for the thermal resistance due to heat conduction; the heat storage due to thermal capacity is associated to the mean wall temperature (in the radial direction). More sophisticated models could be derived to better reproduce the actual radial temperature dynamics, e.g. in thermal stress studies.

3.4.4 Heat exchange modules

The heat flux exchanged between two (or more) objects, such as a fluid flow and a metal wall, is in general a function of the corresponding surface temperatures; therefore, it can be computed by a model interfaced via `DHT` connectors. The `ConvHTE` and `ConvHTC` models

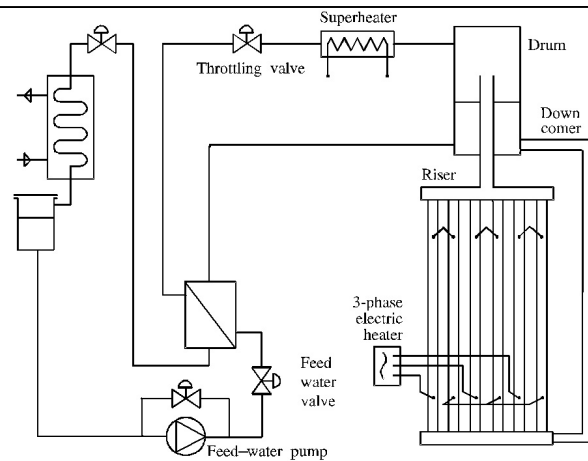

Figure 2: The laboratory plant.

provide simple examples for co-current and counter-current 1D configurations, with given heat exchange coefficient γ . `ConvHTE_gamma` extends the former by using a variable value of γ , provided by the connected object through its `DHT_gamma` connector. More complex configurations can be easily described with a few lines of code.

3.5 Complex physical components

A whole range of heat exchanger models can be assembled using the components described in Section 3.4, depending on physical configuration, operating conditions and desired degree of detail. None of these models probably deserves to be included in the library as such; if a specific aggregate model is to be used many time, the user can easily define it as a new model inside his plant model. Some of them may nevertheless be included in the library to serve as examples.

4 The laboratory plant and data

4.1 Overview

The laboratory plant employed to validate the presented library is a physical model of the evaporating section of a heat-recovery boiler, with a power scaling factor of 1:600. The laboratory plant layout is shown in fig. 2.

To be precise, only the circulating loop of the laboratory plant exactly reproduces the thermo-hydraulic conditions of the real boiler. The other components (preheater, valves, pumps, etc.) provide the correct boundary conditions for the evaporator. In particular,

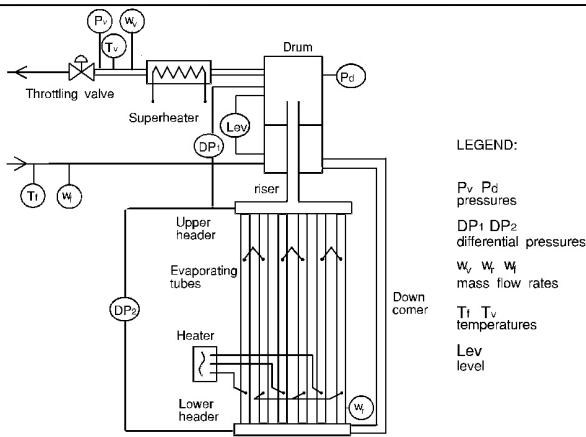

Figure 3: The available plant measurements.

the superheater supplies the necessary (limited) steam superheating to allow a reliable measurement of the steam flow upstream of the throttling valve.

The steam generation takes place at a nominal operating pressure of 60 bar, as in the real plant. The evaporator is made of six electrically heated parallel tubes, one downcomer and a vertical-axis drum, plus the necessary headers and connection tubes. A feed-water valve may be used for drum-level control, and the throttling valve to control the drum pressure. The heat rate to the evaporator is modulated by a power regulator.

The relevant process measurements are summarised in fig. 3; the measurement of the electric power released to the evaporator is also available.

4.2 Plant tests

Many static and dynamic tests were performed on the plant. These tests are plant responses obtained by imposing step variations to the evaporator electric power, the throttling valve position, and the feed-water control valve position. During these tests, the plant was in an open loop. Step variations were given, starting from two different sets of steady-state conditions: the former at high load (around 100% of the maximum load), and the latter at about half load. The boiler pressure was kept nearly proportional to the load: full-load tests were done at about 60 bar, and half-load tests at about 30 bar. Step variations were always imposed both upwards and downwards, their amplitude being in the range 10-15%. Altogether, seventeen step-response tests were executed and logged.

4.3 Data reconciliation

Experimental data coming from the tests were analysed, in order to build a consistent database. The main problem evidenced was a discrepancy between the feed-water and the superheated steam flow rate measurement. Those flow rates must balance at any steady state, as even a small imbalance causes a significant modification of the drum-level transients. Hence, it is very important that the corresponding measurement errors be corrected. In the case at hand, it is assumed that the feed-water flow is error-free (it is in fact much more accurate than the steam flow measurement).

On the basis of steady-state measurements, the calibration constant of the instrument was recomputed. Moreover, to compensate for unpredictable measurement errors, the record of steam flow rate relative to every step response was biased, so as to impose perfect balance at the initial steady state.

A further problem is that the heat rate to the superheater (supplied by an electrical resistor) is not measured. At any steady state, the heat rate Q may be estimated by means of the thermal balance

$$Q = w_v (h_v(p_v, T_v) - h_d), \quad (14)$$

where w_v is the superheated steam mass flow rate, h_d the fluid enthalpy at the drum outlet, and $h_v(p_v, T_v)$ the steam enthalpy at the superheater outlet, evaluated at the local steam temperature T_v and pressure p_v . Unfortunately, h_d is not easy to evaluate because the fluid at the drum outlet is generally wet steam, whose quality x_d is close to one, but unknown. It has been assumed that the steam quality is 1, and $h_d = h_{vs}(p_d)$, where $h_{vs}(p_d)$ is the vapour saturation enthalpy at the drum pressure p_d . Note that a (realistic) wetness of 3%, at 60 bar, yields $h_{vs}(p_d) - h_d \approx 47$ kJ/kg, i.e. a temperature difference of about 14°C at the superheater outlet. In addition, the analysis of experimental data shows that x_d is not constant when the operating condition is changed, but the information available is not sufficient for deriving an empirical correlation for x_d . This is the most important uncertainty in the experimental data, that could not be removed. Fortunately, this uncertainty is relevant only for the superheated steam temperature, while it is almost negligible for the evaluation of the other process variables. The heat rate to the superheater was generally kept constant during any dynamic test. Therefore, its value was computed from the initial steady state, using (14) and the approximation $h_d \approx h_{vs}(p_d)$.

The experimental data records, completed with the corrected steam flow rate and the superheater heat rate, were assumed as the validation database.

5 Experimental validation

5.1 The simulation model

The Modelica diagram of the simulation model is shown in figure 4. This model proves that cases of realistic complexity (i.e., hundreds of differential equations) can be treated effectively. There is not the space to give details. For further information, the reader is referred to the library and model code.

5.2 Model calibration

Steady-state measurements were used to estimate the process parameters affected by an intrinsic uncertainty, i.e. the friction coefficients for the different components in the circulation loop, the friction correlation in the superheater, and the heat losses of the evaporator. For the evaporator, it was assumed that friction obeys to Colebrook's law, and a concentrated pressure drop was introduced upstream of the evaporating tubes, to account for the flow measurement orifices and other flow discontinuities. A multiplicative corrective coefficient was introduced in the second flow equation, and was calibrated with steady-state data to match the circulation flowrate.

The calibration of the friction correlation for the superheater was done selecting the tube roughness so that the relation between the Reynolds number and the friction coefficient matched the points computed from experimental data. As for the evaporator heat losses, considering the evaporator thermal balance at different steady states, it was found that the experimental data fit the formula

$$Q_{lost} = k(T_{wd} - T_{amb}), \quad (15)$$

where Q_{lost} is the lost heat rate, T_{amb} the ambient temperature, and T_{wd} the drum metal wall temperature. Note that Q_{lost} is typically around 10% of the input electrical power, and varies significantly with the drum pressure.

5.3 Individual validation of components

Individual validation of a component can be carried out for components when the available measurements supply complete boundary conditions for that component. In the case presented, only the model of the

choked-flow valve could be validated individually, since all its boundary conditions (inlet steam pressure, flow rate and temperature) were measured.

5.4 Global validation of the plant model

The global validation of the whole plant model is aimed specifically at the analysis of relevant alternatives in terms of component modelling and overall model structuring. In the following the validation tests are listed, together with the results achieved from the point of view of modelling. It is important to notice that the tests were made in open loop and applying step stimuli: this leads to very informative results on the model correctness, as no control system can conceal discrepancies between the model outputs and experimental data, and the stimuli cover a frequency range wide enough to evidence the model behaviour with respect to phenomena that are 'fast' with respect to the dominant plant dynamics. It is also worth stressing that the model was calibrated only once (at high load), and no modification to the model parameters was made to perform the various simulations presented.

5.4.1 Heat rate steps

Negative step variations were applied at high load to the electrical power fed to the heating system. Feed-water was not regulated, so the pressure variation due to the heat rate perturbation caused also a variation of the feed-water flow rate. To reproduce the actual conditions, the simulator was fed with the measured feed-water flow rate as an input.

The main result is that the process behaviour is reproduced very accurately, except for the superheated steam temperature. Its measurement is very noisy, however, and its variations are comparable with the errors due to uncertainty on the steam quality at the drum outlet. Recall also that the heat rate released to the superheater is not measured. These facts confirm that the uncertainty exists, is relevant, cannot be eliminated with the available measurements, but is confined to the outlet steam temperature.

An example of these tests is shown in figures 5 and 6, depicting the drum pressure and level transients, respectively. Notice that the pressure dynamics are reproduced correctly over the frequency range that is interesting for control (corresponding to a typical time scale of some tenth or a few hundreds of seconds). This is true thanks to the non-equilibrium model of the drum.

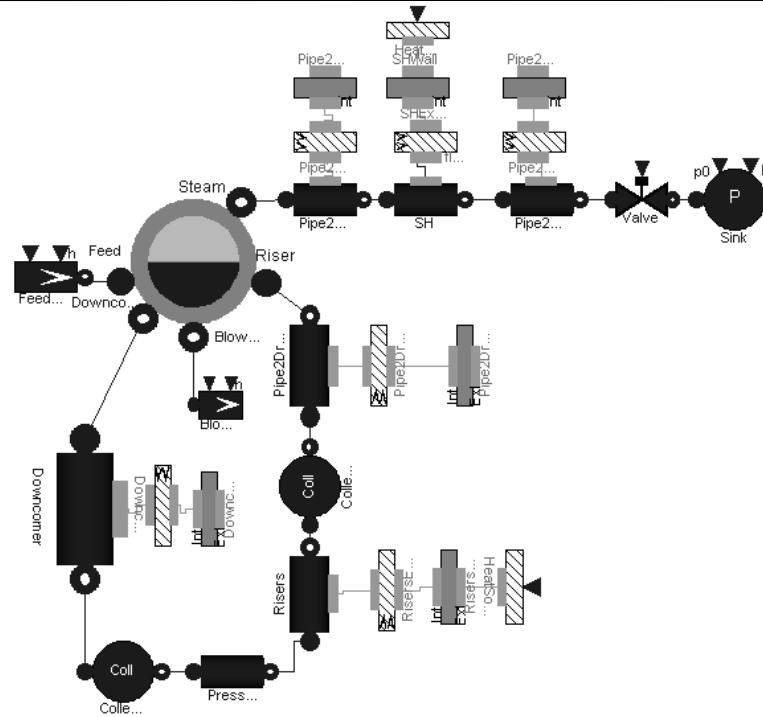

Figure 4: Modelica diagram of the simulation model.

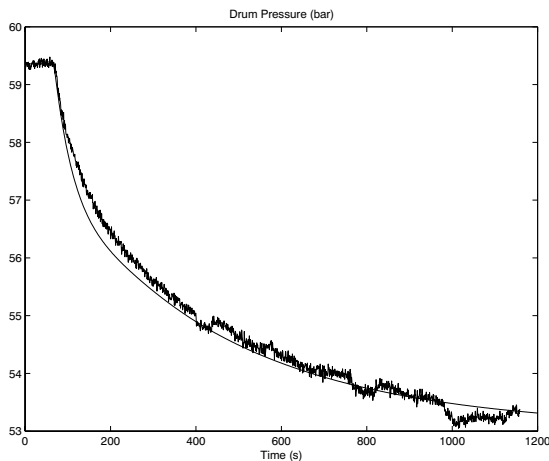

Figure 5: Drum pressure transient for a -10% heat rate step at high load (simulated vs. experimental data).

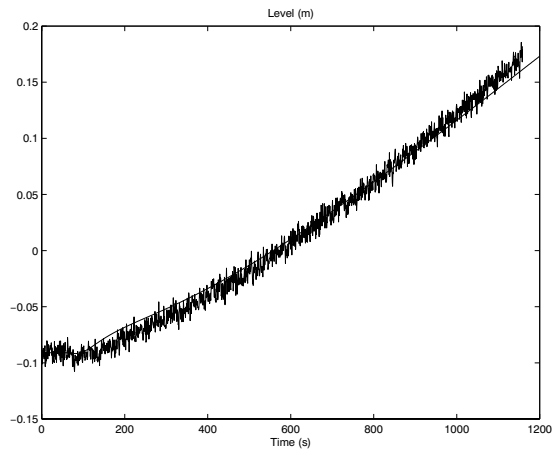

Figure 6: Drum level transient for a -10% heat rate step at high load (simulated vs. experimental data).

5.4.2 Throttling valve steps

Responses to positive and negative throttling valve steps, both at high and low load, showed good agreement between the model output and data. For the reason above, in these tests the feed-water flow rate (that acts as a disturbance) was an input for the simulator. In particular, the non-equilibrium phenomena represented in the drum model allow to reproduce both low-

and mid-frequency dynamics in the pressure responses correctly, and are necessary for this purpose, as witnessed by the effects of the involved parameters (e.g., τ_{ev}) on the responses. Also the effects of thermal exchanges between the fluid in the drum and the drum metal wall were investigated, showing that the corresponding heat transfer coefficient has a significant influence on the superheated steam temperature. This phenomenon is often neglected in the simulation mod-

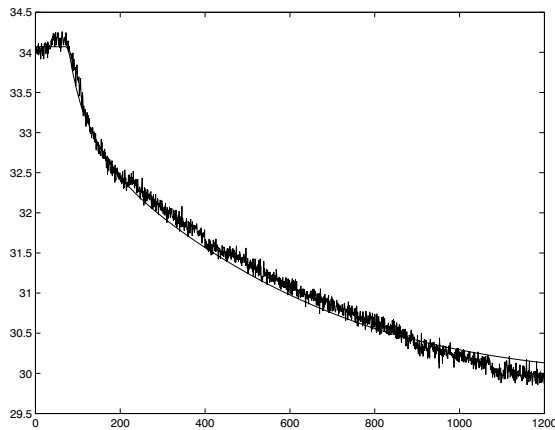

Figure 7: Drum pressure transient for a throttling valve step leading to a 13% pressure reduction at low load (simulated vs. experimental data).

els proposed in the literature.

Figures 7 and 8 reports the drum pressure and the level transients in one of these tests, namely a negative valve step at low load, and confirm the considerations made in the previous section. Notice that in this particular transient bulk boiling actually takes place within the liquid drum subvolume.

5.4.3 Feed-water valve steps

Positive and negative feed-water valve steps were applied. Figure 9 shows the drum level transient in one of these tests, demonstrating good accordance between model and data.

6 Conclusions and work in progress

An open Modelica library for the simulation of thermal power plants has been presented. The library has been used to build a high-fidelity model of a laboratory drum boiler, which has been successfully validated against available data.

The library has been conceived in order to emphasise model readability and extensibility; it contains a limited number of components which nevertheless allow modelling a wide range of different physical components. It should be stressed that the Modelica language allowed translating sophisticated modelling concepts into working code with remarkable ease.

The library is being released to the public, and is open to contribution from other research groups (see URL:

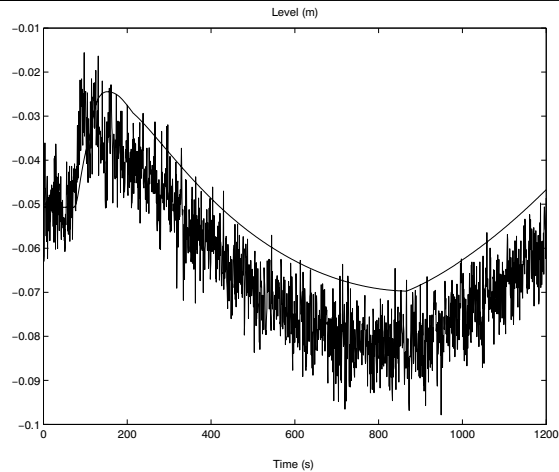

Figure 8: Drum level transient for a throttling valve step leading to a 13% pressure reduction at low load (simulated vs. experimental data).

<http://www.elet.polimi.it/upload/casella/thermopower/>).

The benchmark boiler model together with the experimental data is being released as well.

The development of component models using gases as working fluid (compressor, turbine, combustion chamber, basic components for heat exchangers etc.) and of finite element models for the 1-dimensional fluid flow model is planned for the near future. It could also be interesting to investigate the combined use of the ThermoPower library with control libraries and electro-mechanic libraries to build complete models of power generation equipment.

7 Acknowledgements

The authors are grateful to W. Prandoni and D. Laudato, who realised the physical experiments, and to the CESI research centre (particularly to G. Benelli), who made the relative data available. Many thanks are also due to prof. C. Maffezzoni, for inspiring the presented research and contributing to it with numerous ideas, hints, discussions, and constructive criticisms.

References

- [1] Åström, K.J. and Bell, R.D. (1993), "A nonlinear model for steam generation process", Prepr. 12th IFAC World Congress, Sydney, 3, 395–398.
- [2] Bartolini, A., Leva, A. and Maffezzoni, C. (1995), "Power plant simulator embedded in a

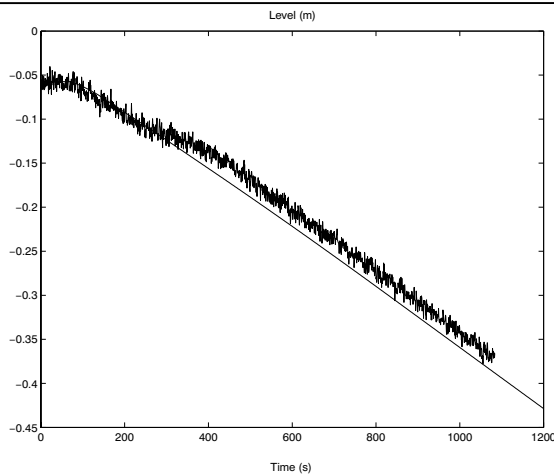

Figure 9: Drum level transient for a feed-water valve step leading to a 40% feed-water mass flow rate reduction at low load (simulated vs. experimental data).

visual programming environment”, Proc. IFAC Conf. SIPOWER 95, Cancún, 119–124.

- [3] Barton, P.I. and Pantelides, C.C. (1994), “Modelling of combined discrete/continuous processes”, *AiChE Journal*, 6, 966–979.
- [4] Breitenacker, F. and Solar, D. (1986), “Models, methods, experiments - modern aspects of simulation languages”, Proc. 2nd European Simulation Conference, Antwerpen, San Diego, 195–199.
- [5] Carpanzano, E., Ferrarini, L. and Maffezzoni, C. (1999), “Simulation environments for industrial process control”, Proc. ESS '99, Erlangen-Nuremberg, 443–450.
- [6] Casella, F. and Leva, A. (2003), “Modelling of distributed thermo-hydraulic processes using Modelica”, Proc. MathMod'03, Wien.
- [7] Casti, J.L. (1992), “Reality rules - picturing the world in mathematics: I, II”, Wiley, New York.
- [8] Chien, K.L., Ergin, E.I., Ling, C. and Lee, A. (1958), “Dynamic analysis of a boiler”, *Trans. ASME*, 80, 1809–1819.
- [9] Collier, J.G. (1981). “Convective boiling and condensation (2nd ed.)”, McGraw-Hill, New York.
- [10] Lausterer, G.K., Franke, J. and Eitelberg, E. (1983), “Modular modelling applied to a Benson boiler”, Proc. 1st IFAC workshop on Modelling and Control of Electric Power Plants, Como.
- [11] Leva, A., Bartolini, A. and Maffezzoni, C. (1998), “A process simulation environment based on visual programming and dynamic decoupling”, *Simulation*, 71(3), 183–193.
- [12] Leva, A., Maffezzoni, C. and Benelli, G. (1999), “Validation of drum boiler models through complete dynamic tests”, *Control Engineering Practice*, 7, 11–26.
- [13] Leva, A. and Maffezzoni, C. (2003), “Modelling of power plants”, in D. Flynn (Ed.), “Thermal power plant simulation and control”, IEE, London, 17–60.
- [14] Maffezzoni, C. (1992), “Issues in modelling and simulation of power plants”, Proc. IFAC Symposium. on Control of Power Plants and Power Systems, Munich, 1, 19–27.
- [15] Maffezzoni, C. and Girelli, R. (1998), “MOSES: modular modelling of physical systems in an object-oriented database”, *Mathematical Modelling of Systems*, 4(2), 121–147.
- [16] Mattsson, S.E., Elmqvist, H. and Otter, M. (1998), “Physical system modeling with Modelica”, *Control Engineering Practice*, 6 (1998), 501–510.
- [17] Oh, M. and Pantelides, C.C. (1996), “Modelling and simulation language for combined lumped and distributed parameter systems”, *Computers & Chemical Engineering*, 6-7, 611–633.
- [18] Perry, R.H. (1984), “Perry’s Chemical engineer’s handbook”, McGraw-Hill, New York.
- [19] Sage, A.P. (1992), “Dynamic systems”, in Atherton, D.P. and Borne, P. (Eds.), “Concise Encyclopedia of Modelling and Simulation”, Pergamon, Oxford, 91–92.
- [20] Troch, I. (1995), “Modelling for optimal control of systems” *Surveys on Mathematics for Industry*, 5, 203–292.
- [21] Tummescheit, H., Eborn, J. and Wagner F.J. (2000), “Development of a Modelica base library for modeling of thermo-hydraulic systems”. Proc. the Modelica Workshop 2000, Lund, 41–50. Library URL: <http://sourceforge.net/projects/thermofluid>.