



# MODELICA

Proceedings  
of the 3<sup>rd</sup> International Modelica Conference,  
Linköping, November 3-4, 2003,  
Peter Fritzson (editor)

Stefan Heller, Tilman Bünte  
TU München; DLR Oberpfaffenhofen, Germany:  
Modelica Vehicle dynamics library: Implementation of driving  
maneuvers and a controller for active car steering  
pp. 19-28

Paper presented at the 3<sup>rd</sup> International Modelica Conference, November 3-4, 2003,  
Linköpings Universitet, Linköping, Sweden, organized by The Modelica Association  
and Institutionen för datavetenskap, Linköpings universitet

All papers of this conference can be downloaded from  
<http://www.Modelica.org/Conference2003/papers.shtml>

#### Program Committee

- Peter Fritzson, PELAB, Department of Computer and Information Science, Linköping University, Sweden (Chairman of the committee).
- Bernhard Bachmann, Fachhochschule Bielefeld, Bielefeld, Germany.
- Hilding Elmqvist, Dynasim AB, Sweden.
- Martin Otter, Institute of Robotics and Mechatronics at DLR Research Center, Oberpfaffenhofen, Germany.
- Michael Tiller, Ford Motor Company, Dearborn, USA.
- Hubertus Tummescheit, UTRC, Hartford, USA, and PELAB, Department of Computer and Information Science, Linköping University, Sweden.

Local Organization: Vadim Engelson (Chairman of local organization), Bodil Mattsson-Kihlström, Peter Fritzson.

# MODELICA vehicle dynamics library: Implementation of driving maneuvers and a controller for active car steering

Stefan Heller\*

Technische Universität München (TUM),  
Institute for Real-Time Computer Systems (RCS),  
D-80290 München, Germany

Tilman Bunte†

German Aerospace Center (DLR),  
Institute of Robotics and Mechatronics,  
Oberpfaffenhofen, D-82230 Wessling,  
Germany

## Abstract

This paper deals with the assessment and exploitation of the recently released MODELICA-based vehicle dynamics library. A setup of various driving maneuvers is accomplished. These maneuvers will be conducted by providing steering angle and gas/brake position to the car model of the library. The common linearized single track model is derived as an approximative model for the fully detailed vehicle dynamics model. This model is used for synthesis of feedforward control and later also as a nominal model for active car steering control aiming at vehicle dynamics stability improvement. The applied robust steering controller structure is known as the disturbance observer. Simulations are used to demonstrate the effectiveness of the vehicle dynamics enhancement in comparison to the uncontrolled vehicle. Also some experiences with the vehicle dynamics library are pointed out.

## 1 Introduction

As a rather recent field of research the simulation of multiphysical objects gets more and more weight. The behaviour of car models during maneuvers is of interest, e. g. for research and development of cars. The general ability of executing the simulations in real time is important for hardware-in-the-loop investigations. The MODELICA language is able to handle multiphysical objects. Concerning the

real time ability MODELICA comprises some powerful promising features: *hybrid modelling*, *inline integrators* and *symbolic preprocessing*.

The MODELICA vehicle dynamics library [1] basically consists of a detailed mathematical model comprising the governing multibody differential equations. Moreover, there are some rudimental steering schedules for conducting simple maneuvers. This library is also appropriate for the analysis, synthesis and evaluation of control systems concerning vehicle dynamics. All considerations in this paper refer to an unofficial prerelease of the *vehicle dynamics library* [1] and particularly to the *chassis level 2*. The library and some significant features will be outlined in section 2. For the setup of more sophisticated and realistic maneuvers a generic driver module is needed, which represents the action of a real driver. This driver module conducts the maneuvers and is therefore called *maneuver control* block.

The *single track model* is used as an approximative model for the more detailed car model. It is used for the synthesis of a lateral acceleration controller which is contained in the *maneuver control* block. The identification of the parameters of the single track model is explained and the parameters are given in section 3. The *maneuver control* block is introduced in section 4. The lateral acceleration controller provides steering wheel angle suitable for following a predefined lateral acceleration profile. Alternatively, the steering angle can be provided directly to the car model. Analogue is the setting of the position of the gas/brake pedal. This position and hence the speed of the car model are controlled according to a predefined speed profile.

Maneuvers executing full braking need ABS-functionality. Therefore, a wheel slip controller

\*e-mail: Stefan.Heller@mytum.de

†e-mail: Tilman.Buente@dlr.de

is introduced in section 5 which approximates the function of a real ABS-system.

Section 6 deals with the application of the *maneuver control* block. Four maneuvers are conducted which illustrate the action of this block. Also the car model of the vehicle dynamics library is evaluated by means of these maneuvers. Moreover, the maneuvers *braking in a curve* and  *$\mu$ -split braking* demonstrate the operation of the added wheel slip controller.

In section 7 the active car steering controller for improvement of yaw dynamics is introduced. When the car model is exposed to asymmetric conditions like asymmetric load, side wind or asymmetric road friction while braking critical yaw dynamics can cause instability of the car. This instability can be reduced and the car can be brought back into safe state by active car steering. The controller used in this paper is known as the *disturbance observer* [2]. It determines an additional steering angle which is superimposed mechanically to the steering wheel angle.

The controlled car is evaluated in section 8 by comparing simulations of the maneuvers to simulations with the conventional car.

Finally, section 9 reports on some experiences about working with the vehicle dynamics library.

## 2 MODELICA vehicle dynamics library

The vehicle dynamics library [1] is structured hierarchically using four levels. The uppermost level is called the *vehicle level* and contains the total model of the car. This car model can optionally be completed by a power-train, brakes, a block which has the function of a driver, and environmental conditions, like certain roadtypes (friction) or aerodynamics. On the next level the *chassis* components are modeled explicitly, e. g. with a front and a rear suspension, wheels and body. The *suspension level* allows the reconfiguration of a car with different suspensions. Therefore, the suspensions have the same interface. The lowest level is the *component level* with components like trailing arms, struts, linkages etc. which are based on the standard MODELICA and ModelicaAdditions libraries.

Fig. 1 shows our final setup from the *vehicle level* for simulating the maneuvers with active car steering. The dotted connections indicate the transmission of the signals on the actual state of the car: speed  $v_x$ ,

lateral acceleration  $a_y$ , position and orientation to the *maneuver control* block; yaw rate  $r$  and speed  $v_x$  to the *Vehicle Dynamics Control (VDC)* block; speed  $v_i$  and rotational speed  $\omega_i$  of each wheel to the wheel slip controller.

The gray connections refer to the steering angle signals. During maneuvers with the conventional car, the VDC block is inactive. Hence, the steering angle from the *maneuver control* block is equivalent to the input steering angle at the car model. The thin gray connections are for transmission of the reference and the actual additional steering wheel angle between VDC block and *mechanical steering angle addition* block.

The value for the gas/brake pedal position in the *maneuver control* block is passed to the wheel slip controller block. For a positive value the acceleration is carried out by equal propelling torques on both wheels of the rear axle. A negative value for the pedal position means braking. Then the deceleration command is distributed on the brakes of the four wheels according to the wheel slip control. The black bondings represent the propelling torques (solid) and braking torques (dashed) of the wheels.

The steering angle is passed to the car model by use of the *position element* of the Mechanics Package of MODELICA. The position element is accordingly used as interface for the gas/brake pedal position. In the latter case the only additional feature is the dependence on the signed value (as described before).

## 3 Single track model parameters

For controller design the common linearized single track model [2][3] is employed as an approximative model for the fully detailed vehicle dynamics model. For example, the steady state gain  $G_V|_{s=0}$  from steering wheel angle  $\delta_L$  to lateral acceleration  $a_{ydef}$  is needed to implement feedforward control for the steering controller in the *maneuver control* block. Hence, first the parameters of the single track model are identified.

The single track model parameters corresponding to the fully detailed vehicle dynamics model are determined by an optimization aiming at best matching of the simulation results for both steady state cornering and dynamic maneuvers. The parameters given in Tab 1 are the single track parameters for the car model in

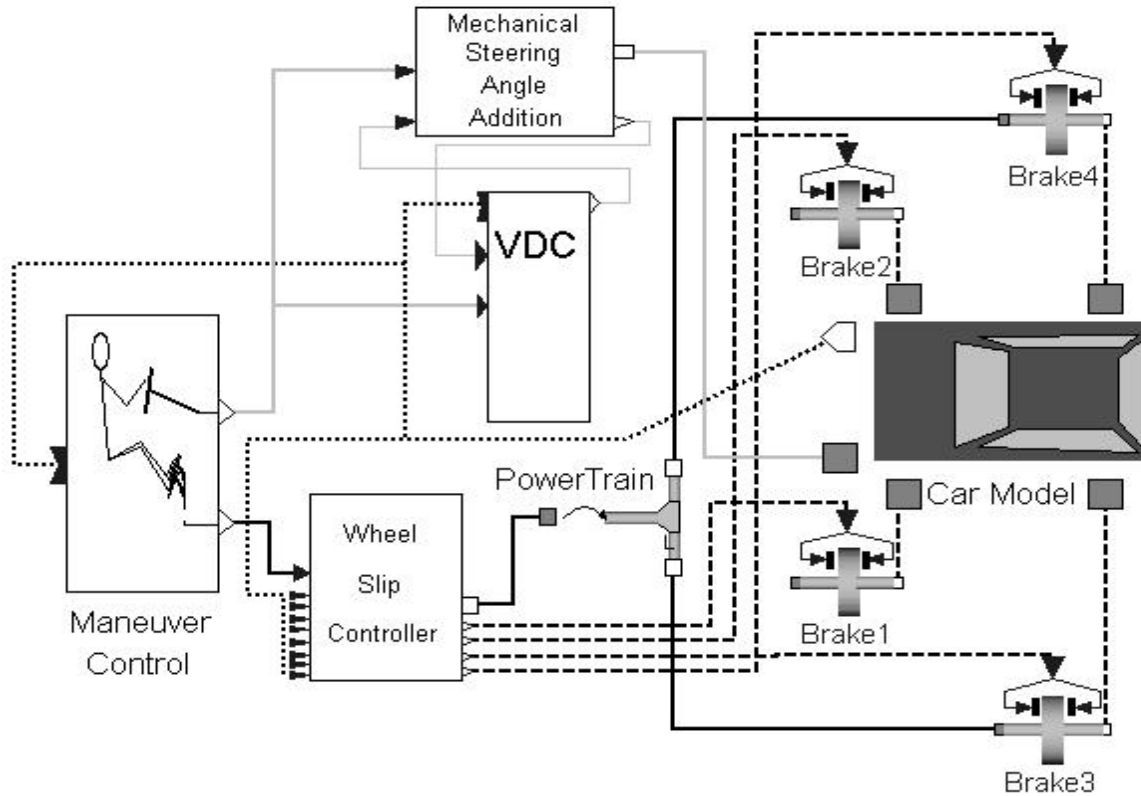

Figure 1: structure of the simulation set up with active car steering controller

the vehicle dynamics library (which is by default parameterized as a BMW 3-series).

#### 4 The maneuver control block

As mentioned before, this *maneuver control* block is a model for the real driver’s actions which are necessary to perform a certain maneuver. It operates the steering angle and gas/brake pedals of the car model. This block needs information on the actual dynamic state of the car i.e. virtual measurement signals of the actual speed  $v_x$  and the lateral acceleration  $a_y$ . The *maneuver control* block consists of a lateral dynamics controller (Fig. 2) and a speed controller (Fig. 3).

Table 1: Identified parameters of the single track model

mass	$m$	1482.9 kg
distance from front axle to center of gravity	$l_f$	1.0203m
distance from rear axle to center of gravity	$l_r$	1.5297m
tire cornering stiffness of the front wheels	$c_f$	$91776 \frac{N}{rad}$
tire cornering stiffness of the back wheels	$c_r$	$77576 \frac{N}{rad}$
transfer constant angle steering wheel to angle front wheel	$i_L$	16.94
moment of inertia w.r.t. the vertical axis through centre of gravity	$J$	$2200 \text{kgm}^2$

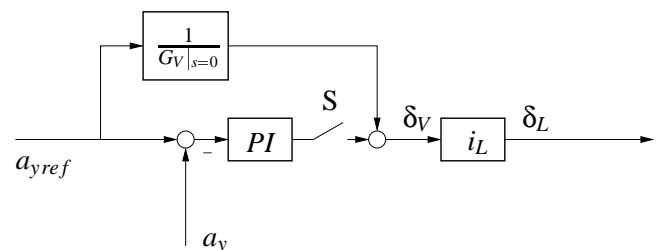

Figure 2: Controller for providing steering wheel angle according to a predefined lateral acceleration profile

The total steering wheel angle output by this block is composed of a feedforward and a feedback part which

may individually be hooked up as adequate for a specific maneuver (Fig. 2). For some maneuvers, a mere feedforward steering is sufficient. For others maintaining a certain lateral acceleration requires feedback control (this means incorporating the PI-controller by closing switch S in Fig. 2). The block  $i_L$  is the gear ratio between steering wheel angle  $\delta_L$  and average steering angle at the two front wheels.

Similarly to the steering angle controller the speed controller (Fig. 3) consists of a feedforward and a feedback part.

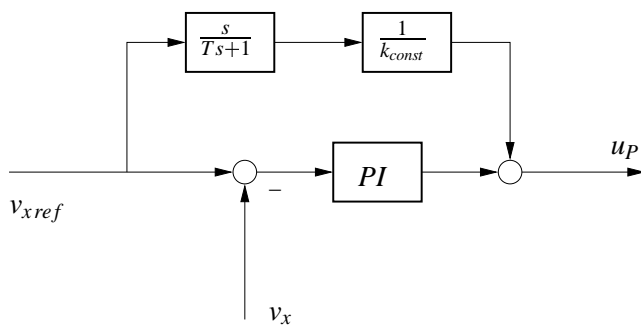

Figure 3: Controller for the position of the gas/brake pedal

The feedforward control is based on the assumption that the actual longitudinal acceleration is proportional to the gas/brake pedal position  $u_p$ :

$$a_x = \frac{1}{s} v_x = k_{const} u_p \quad (1)$$

For the model of the library it is  $k_{const} = 0.0025\text{m/s}^2$ . This relation has been validated by several simulations. The inverse is used for feedforward control. The low pass filter in Fig. 3 is added for making the included differentiator causal.

## 5 Wheel slip controller

To be able to execute full braking an ABS-functionality is needed. Therefore, the actual speed  $v_i$  and rotational speed  $\omega_i$  of each wheel must be known from the car model to calculate the actual longitudinal slip at each wheel (with (2)).  $R$  is the radius of the wheels.

$$S_i = 1 - \frac{R \omega_i}{v_{xi}} \quad (2)$$

These slips  $S_i$  are then used to calculate the average slip  $S_{avg}$  of the four wheels:  $S_{avg} = \sum_{i=1}^4 \frac{S_i}{4}$ . The slip controlled braking force  $T_{Bi} =$

$\frac{1}{4} (1 - |S_i|) (1 - S_{avg}) T_P$  is then calculated with the braking force at the pedal  $T_P$  for each wheel.

This ensures that the brake torque at the brake pedal is distributed on the brakes of each wheel according to the slip at the wheel. Blocking of a wheel is avoided and the vehicle remains controllable. The wheel slip controller was designed heuristically to copy the basic ABS functionality. In our simulations it turned out that it works satisfactory (see next section).

## 6 Driving maneuvers

Four different maneuvers have been chosen from [4]. This election is made in regard to expressiveness of the maneuvers to evaluate both the usage of the vehicle dynamics library and the car model and also the performance of a active steering controller for vehicle dynamics. At first, the conventional car (without additional steering) is considered. Therefore, the VDC block is inactive.

**Maneuver: steady state cornering** . This maneuver is conducted by maintaining a constant lateral acceleration which is adjusted by the steering wheel controller from Fig. 2. Starting from a maximum value, the speed is slowly decreased to cover a certain speed operating domain.

Fig. 4 shows the results of maneuver *steady state cornering*. To maintain a constant lateral acceleration  $a_y$  during a constant decline of speed  $v_x$  the steering wheel angle  $\delta_L$  rises.

**Maneuver: braking in a curve** For this maneuver the steering wheel angle is kept constant. Full braking is applied. Simulation results are shown in Fig. 5.

When the braking is applied the vehicle is in the state of a left turn with high lateral acceleration ( $\approx 6\text{m/s}^2$ ). Fig. 5e shows the slip at the wheels. The rear left wheel encounters the least vertical load. Therefore, its slip exceeds the other wheels. However, the braking force at this wheel is reduced by the slip controller (Fig. 5f, 5h). Hence the slip remains limited and blocking of the wheels is prevented.

**Maneuver: sequence of alternating steering wheel angle steps** . A so called *lateral acceleration level*

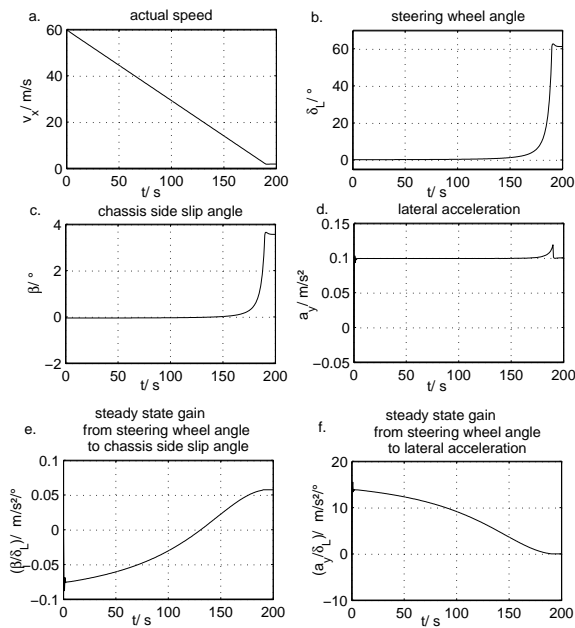

Figure 4: Simulation results of the maneuver *steady state cornering*

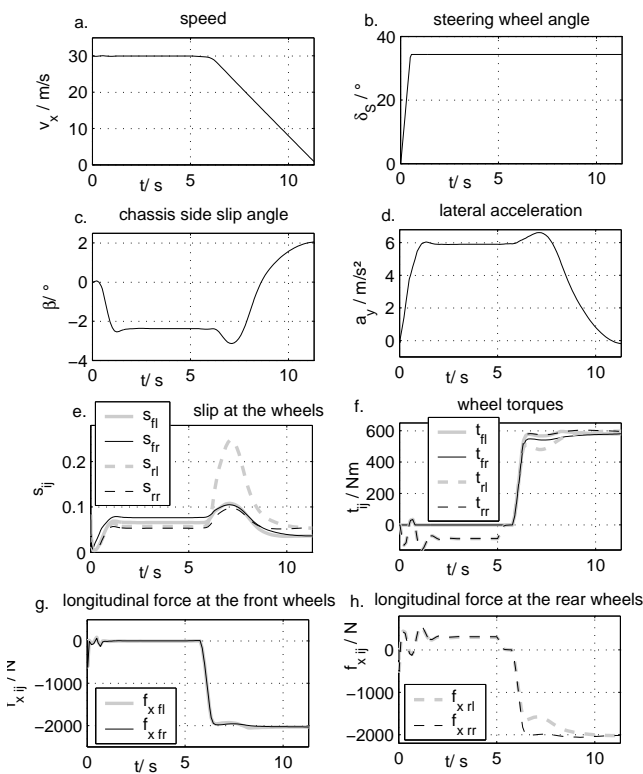

Figure 5: Simulation results of maneuver *braking in a curve* (indices: i= front,rear; j=right,left)

needs to be assigned prior to the simulation. The steering wheel angle is periodically switched between opposite values depending on the actual speed. The step height is computed from the single track model such that it corresponds to a steady state lateral acceleration being equal to the preassigned lateral acceleration level. Again, speed is decreased slowly to cover a certain speed range (Fig. 6). The resulting lateral ac-

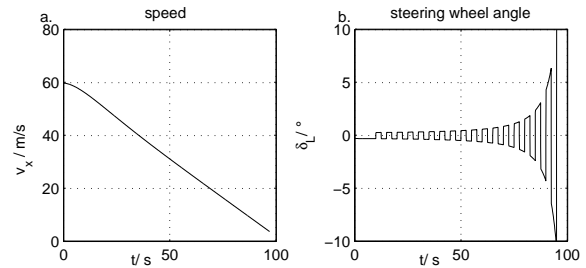

Figure 6: Speed  $v_x$  and lateral acceleration  $a_y$  of maneuver *sequence of alternating steering angle steps*

celeration (Fig. 7) gives information on the dynamic steering responses of the car model.

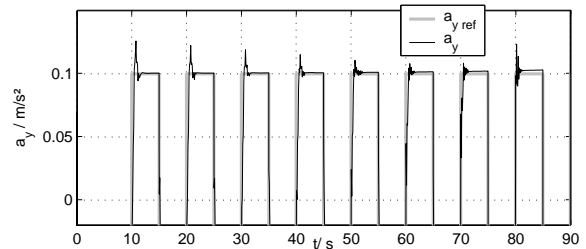

Figure 7: Simulation results of maneuver *sequence of alternating steering angle steps*

**Maneuver:  $\mu$ -split braking** . The steering wheel angle is zero ( $\delta_L = 0^\circ$ ) and not changed during the whole maneuver. Initially the car model is driven at constant speed (initial value:  $v_{x0} = 30\text{m/s}$ ). Then the car model is driven along parallel lanes with different friction. The wheels on the right side of the car drive on the lane with low friction ( $\mu = 0.4$ ). When the braking is applied the asymmetric road friction at the wheels causes a disturbing yaw moment. It is expected that the wheels on the lane with low friction, are less detained and therefore the direction of the car tends towards the lane with higher friction. Fig. 8 shows the results of the simulation. The friction of the road under the right wheels is reduced to  $\mu = 0.4$  and as expected rises again to  $\mu = 1$  (Fig. 8 b) when the wheels enter the left lane. The stroboscopic diagram in Fig.

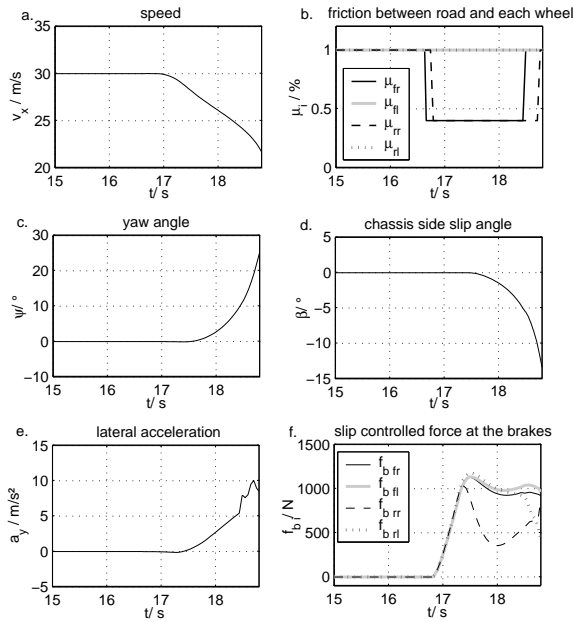

Figure 8: Simulation results of the maneuver *μ-split braking*

9 shows the course of the vehicle from bird's eye view.

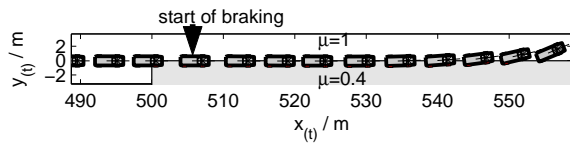

Figure 9: Stroboscopic recorded course of the maneuver *μ-split braking*

## 7 Controller for active car steering

The effect of the yaw disturbance torque shall now be reduced by adding a controller for active car steering. To improve the yaw dynamics of the vehicle a robust steering controller known as the disturbance observer [2] is added. This two degree of freedom control architecture is used to improve vehicle handling and to achieve better disturbance rejection.

The controller synthesis is based on the equation (3) which describes the yaw dynamics of the vehicle model [2].

$$r = G\delta_V + d \quad (3)$$

$G$  is the transfer function between steering angle  $\delta_V$  at the front wheels and the yaw rate  $r$ . The external disturbances are  $d$ . In equation (4) an adopted nominal model  $G_N$  and a multiplicative model uncertainty  $\Delta_M$  are used for description of  $G$ .

$$r = (G_N(1 + \Delta_M))\delta_V + d \quad (4)$$

The aim of the controller is to obtain the transfer function in (5) despite model uncertainty  $\Delta_M$  and external disturbance  $d$  ( $\delta_L$  is the steering wheel angle).

$$\frac{r}{\delta_L} = G_N \quad (5)$$

External disturbance and model uncertainty are treated as an extended disturbance  $e$  (eq. (6) and (7)).

$$r = G_N\delta_V + (G_N\Delta_M\delta_V + d) = G_N\delta_V + e \quad (6)$$

$$e = r - G_N\delta_V \quad (7)$$

The front steering angle  $\delta_V$  is set according to (8).

$$\delta_V = \delta_L + \delta_C \quad (8)$$

$$\delta_C = -G_A \frac{e}{G_N} = G_A \left( \delta_V - \frac{r}{G_N} \right) \quad (9)$$

The additive steering angle  $\delta_C$  provided by the VDC block is the output of the steering actuator  $G_A$  (9). Eq. (5) is approximated best with an ideal actuator ( $G_A \rightarrow 1$ ). For implementation, the feedback signals  $r$  and  $\delta_V$  are lowpass filtered to limit the controller to low and medium frequency domain. The relative degree of the low pass filter  $Q$  is chosen to be at least equal to the relative degree of  $G_N$  for causality of  $Q/G_N$ . The filter  $Q$  is chosen according to (10)

$$Q = \frac{1}{\tau_Q s + 1} \quad (10)$$

The structure of the controller according to equation (11) is shown in Fig. 10.

$$\delta_V = \delta_L + G_A \left( Q \delta_V - \frac{Q}{G_N} r \right) \quad (11)$$

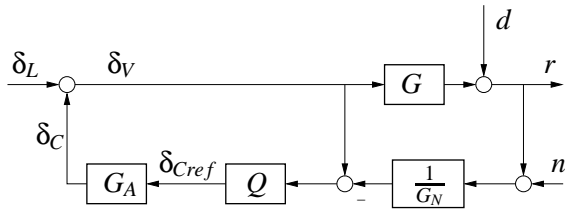

Figure 10: structure of the *Disturbance Observer*

The transfer function is given in eq. (12).

$$\frac{r}{\delta_L} = \frac{G_N G}{G_N (1 - G_A Q) + G_A G Q} \quad (12)$$

Here, as nominal model, the dynamics of the *single track model* is implemented. The virtue of this controller is described in detail in [2]. For physical implementation "additional steering" is assumed, i. e. mechanical superposition of the steering wheel angle  $\delta_L$  and the output of the actuator. In the model of the actively steered car (1), the controller (11) is implemented in the *VDC* block. A simple actuator model is implemented as part of the *mechanical steering angle addition* block.

## 8 Comparing maneuvers with active car steering to conventional conducted maneuvers

Finally, the car model with the active steering controller is compared with the conventional car. Therefore, the simulation results of four maneuvers are discussed. Both the conventional and the controlled car are displayed.

**Maneuver: braking in a curve** . This maneuver is known from section 6. The *VDC* block provides a steering angle  $\delta_C$  which is added to the steering wheel angle  $\delta_L$ . As shown in Fig. 11 the additive steering angle first raises because the nominal model is valid for the linear operating range of the tire characteristics, whereas in the simulation the lateral wheel forces are already close to their saturation. Also the yaw rate

$r$  and the lateral acceleration  $a_y$  are shown. When the braking causes a disturbing yaw moment the additive steering angle is reduced to compensate for this oversteering. The cause of the temporary oscillations of  $a_y$  in Fig. 11 seems to be due to a (yet unclear) imperfection of the car model.

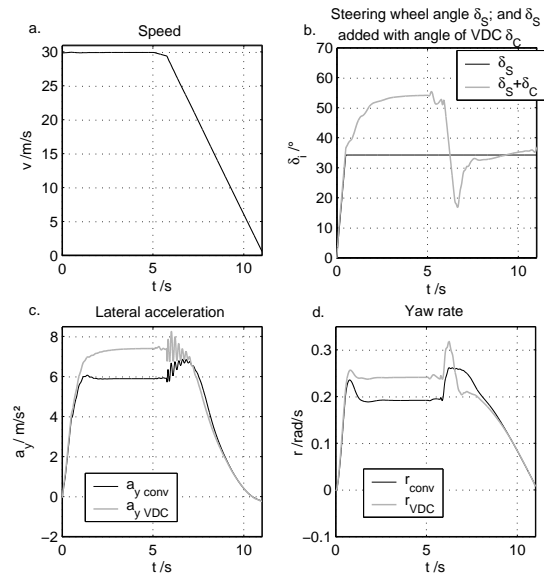

Figure 11: Comparing maneuver *braking in curve*

**Maneuver: double lane change** . Maneuver *double lane change* is used for assessment of car dynamics in research and development of both vehicles and control systems for vehicle dynamics. The speed of the vehicle is kept constant during the whole maneuver ( $v_x = 30\text{m/s}$ ). Resulting from one period of a sinusoidal steering angle input the vehicle completes a single lane change. The lane change back is caused by a corresponding steering input in the opposite direction. For the assessment of the vehicle model of the *MODELICA* library the amplitude of the sinusoidal steering angle and the time between the two sinusoidal signals are adapted until the course of the vehicle (y-position in Fig. 12 b.) fulfills the requirements of the standardized *double lane change* (according to ISO 3888; the boundaries of this course are marked in Fig. 12 b.). This maneuver is performed as an *open loop* maneuver, i. e. the drivers steering wheel input is not affected by the course of the vehicle. For a better agreement with reality, the *maneuver control* block needs to be enhanced by a more sophisticated driver model in the future. Nevertheless, in Fig. 12 the stability enhancing effect of the controller can be recognized.



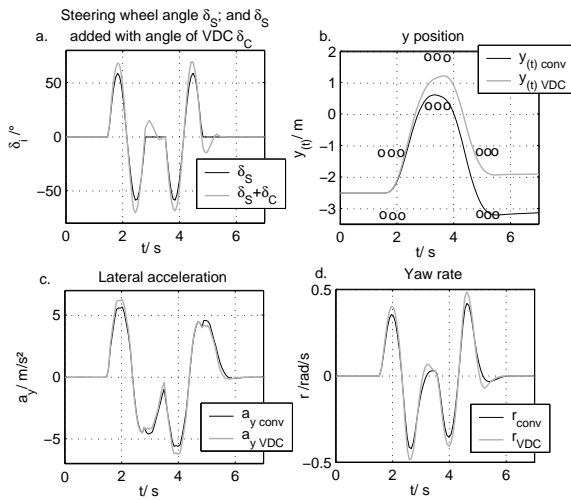

Figure 12: Comparing maneuver *double lane change*

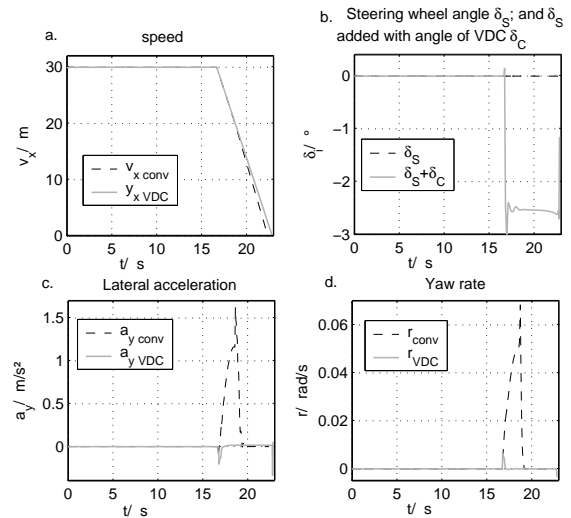

Figure 14: Comparing maneuver  *$\mu$ -split braking*

**Maneuver: sequence of alternating steering wheel angle steps**. This maneuver shows how the controller affects the steering transfer function of the vehicle over the entire speed operating domain. The speed is slowly but continuously increased. Apart from that the simulation is executed similarly as described in section 6. Fig. 13 shows the results of the maneuver

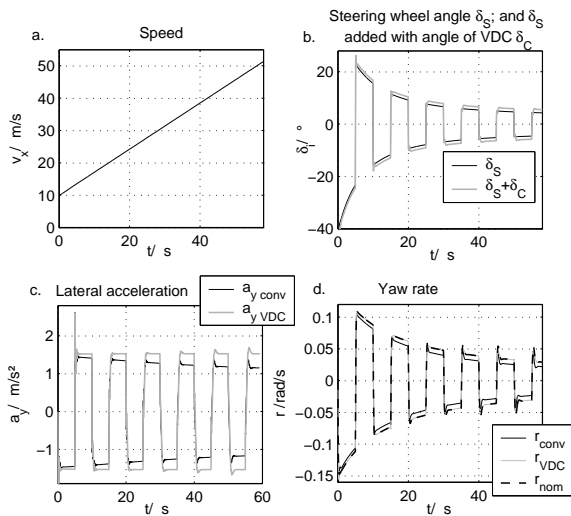

Figure 13: Comparing maneuver *sequence of alternating steering angle steps*

ver simulations. The controller’s aim is to make the yaw rate close to the nominal model despite of disturbances.

**Maneuver:  $\mu$ -split braking**. This maneuver is already known from section 6.

Fig. 14 shows the results of the maneuver simulations.

For better clearness the lines of the conventional vehicle are printed dashed.

When braking is applied with the controlled car an additional steering angle  $\delta_C$  (Fig. 14 b.) compensates for the increasing yaw rate (Fig. 14 c. and d.). This can also be seen in the stroboscopic diagram in Fig. 15. Compared to the conventional  $\mu$ -split braking (Fig. 9), the distinct stability improvement is obvious. A small

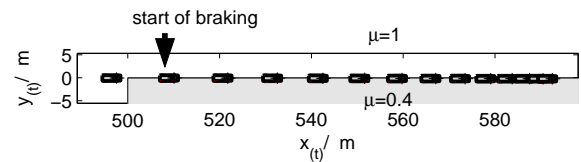

Figure 15: Stroboscopic recorded course of the maneuver  *$\mu$ -split braking* with active steering controller. (Compare to Fig. 9)

divergence is still present.

## 9 Experiences with vehicle dynamics library

From a user’s point of view, the general advantage of working with a vehicle dynamics model based on MODELICA is its transparency and, as a matter of course, the feasibility of multidisciplinary modelling. Due to the component oriented philosophy, user-specific enhancements to a car model taken from the vehicle dynamics library may easily be accomplished. Our specific comments refer to an unofficial pre-release version of vehicle dynamics library [1],

and particularly to the *chassis level 2*. Therefore, our records may not be applicable to the consecutively released versions. As far as our experiences with the vehicle dynamics library on the basis of the investigated maneuvers are concerned, the simulation results are commensurate with a typical mid-size passenger car. The performance of the simulated vehicle appears to be plausible and realistic but two exceptions which are reported below. Firstly, during maneuvers where the lateral vehicle dynamics is explicitly excited (e.g. braking in a curve and alternating steering wheel steps) poorly damped oscillations at 4Hz of the lateral acceleration occur at all speeds (see Figs. 7,11,13). We act on the assumption that this effect is not realistic and the model should be reviewed in this regard. Secondly, a strange phenomenon appears during the  $\mu$ -split braking maneuver. In the period between entering the low friction lane (*low  $\mu$* ) and the start of the full braking a remarkable yaw disturbance torque is generated which at first make the vehicle turn towards the low- $\mu$  lane. This effect may be explained by the reduction of the lateral force which is due to the toe-in angle of the front tire on the low- $\mu$  side. However, the effect of this fact seems to be much too excessive compared to reality. We guess that checking the tire model will solve this problem.

## 10 Conclusions

The vehicle dynamics library was assessed and exploited in this paper. The single track parameters for the vehicle model of the library were identified. With these parameters feedforward control for the setup of various driving maneuvers was implemented. The maneuvers were conducted by providing steering angle and gas/brake. Also feedback control was implemented for this maneuvers. A robust steering controller for active car steering was introduced and implemented. The stability enhancement concerning the yaw dynamics of the vehicle was shown by execution of significant maneuvers. The model with active car steering controller was compared with the conventional model by means of these maneuvers.

## 11 Acknowledgement

The authors want to thank Univ.-Prof. Georg Färber and Dipl.-Ing. Philipp Harms from the Institute for

Real-Time Computer Systems (RCS) of the Technical University Munich (TUM) for their scientific support.

## References

- [1] J. Andreasson, "Vehicle dynamics library." 3rd International Modelica Conference, Linköping, 2003.
- [2] T. Bunte, D. Odenthal, B. Aksun Güvenc, and L. Güvenc, "Robust vehicle steering control design based on the disturbance observer," *Annual Reviews in Control*, vol. 26, pp. 139–149, 2002.
- [3] P. Riekert and T. Schunck, "Zur Fahrmechanik des gummibereiften Kraftfahrzeugs," *Ingenieur Archiv*, vol. 11, pp. 210–224, 1940.
- [4] S. Beiker, "Verbesserungsmöglichkeiten des Fahrverhaltens von Pkw durch zusammenwirkende Regelsysteme." Fortschritt-Bericht, 2000.

